

Adjustable Jig Fixture

For Tamp-Blow Labeling Systems

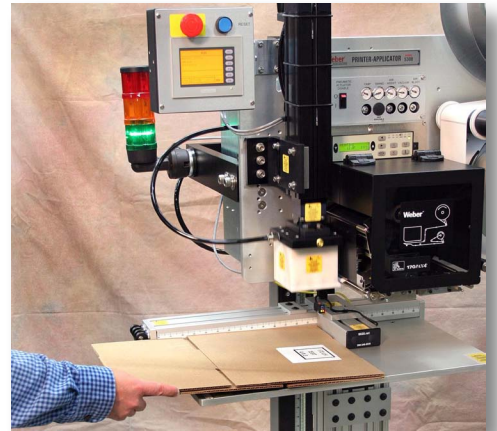

This adjustable jig fixture helps ease the transition from manual to semi-automatic labeling using a Weber tamp-blow, pressure-sensitive label applicator or printer-applicator.

The jig fixture is designed exclusively for easy attachment to Weber's heavy-duty t-base stand, which provides a secure mount for both the fixture and a Weber labeling system. The jig fixture's sturdy table and adjustable X and Y axis fences and recessed scales provide a workstation that facilitates operator involvement.

Quick-release knobs and levers enable the operator to adjust the guide fences to accommodate products or packages from 5" to 20.5" wide. Label application is activated through the use of a footswitch or convergent proximity sensor.

The jig fixture's t-base mount, table and adjustable fences are constructed of durable, lightweight aluminum. The unit's working surface consists of over 440 square inches.

KEY FEATURES

- Works with all Weber tamp-blow label applicators and printer-applicators
- Easy to adjust and use
- Built from rugged, lightweight aluminum

Adjustable Jig Fixture

For Tamp-Blow Labeling Systems

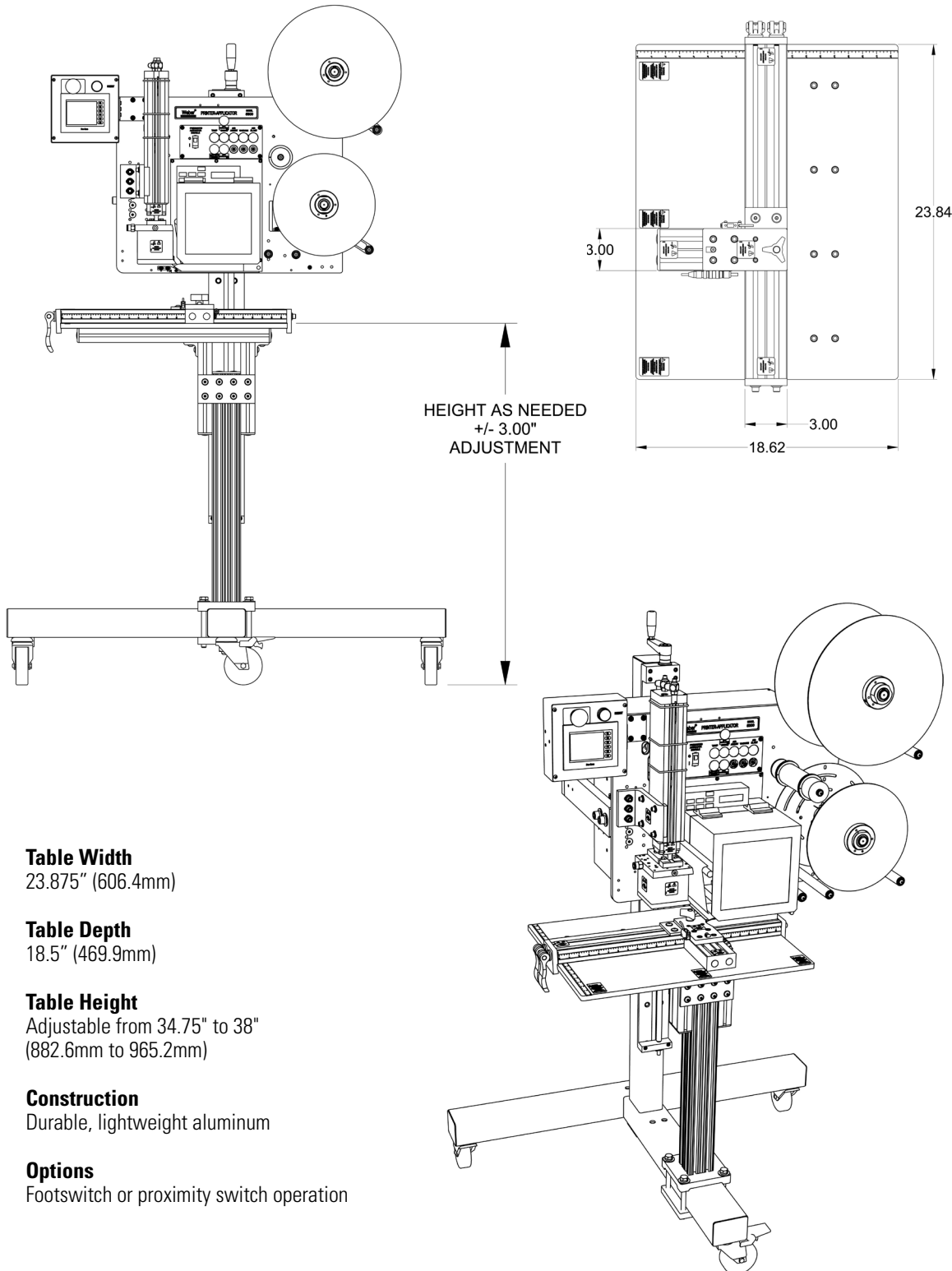

Table Width
23.875" (606.4mm)

Table Depth
18.5" (469.9mm)

Table Height
Adjustable from 34.75" to 38"
(882.6mm to 965.2mm)

Construction
Durable, lightweight aluminum

Options
Footswitch or proximity switch operation

Weber Packaging Solutions, Inc.

World Headquarters
Weber Packaging Solutions, Inc.
711 W. Algonquin Road
Arlington Heights, IL 60005-4457
Phone: 847.364.8500
Fax: 847.364.8575
info@weberpackaging.com
www.weberpackaging.com

Canada
Weber Marking Systems of Canada
6180 Danville Road
Mississauga, Ontario L5T 2H7
Phone: 905.564.6881
Fax: 905.564.6886
info@webermarking.ca
www.webermarking.ca

United Kingdom
Weber Marking Systems UK
Macmerry Industrial Estate
Tranent, East Lothian EH33 1HD
Scotland
Phone: +44.187561.1111
Fax: +44.187561.3310
sales@weber.co.uk
www.weber.co.uk

Germany
Weber Marking Systems GmbH
Maarweg 33
D-53619 Rheinbreitbach
Germany
Phone: +49.2224.77080
Fax: +49.2224.770820
info@webermarking.de
www.webermarking.de
www.bluhmsysteme.com

Thailand
Weber Marking Systems (Thailand), Ltd.
39/73 Samutsakom Industrial Estate
Moo 2, Rama 2 Road,
Bang Ka-Jao, Muang,
Samutsakom 74000, Thailand
Phone: +66.34.490639
Fax: +66.34.490.638
E-mail: sales@weber.co.th

Belgium
Weber Marking Systems SA
Interleuvenlaan Nr. 23, Bus 2
3001 Leuven-Heverlee, Belgium
Phone: +32.16.38.79.50
Fax: +32.16.38.79.59
E-Mail: info@webermarking.be

Denmark
Bluhm Danmark A/S
Nordkrogen 7
DK-7300 Jelling, Denmark
Phone: +45.75.87.26.00
Fax: +45.75.87.26.10
salesdk@bluhmsysteme.com
www.bluhmsysteme.dk

France
Weber France S.A.
ZI de Montaudran
15, impasse Didier Daurat-BP 44419
31 405 Toulouse Cedex 4- France
Phone: +33.562.47.2737
Fax: +33.562.47.1626
weber@webermarking.fr
www.webermarking.fr

Austria
Bluhm Systeme GmbH
Rüstorf 82
A-4690 Schwanenstadt, Austria
Phone: +43.7673.4972.15
Fax: +43.7673.4974
gresch@bluhmsysteme.com

Ireland
Weber Labelling & Coding Ltd.
Kilcannon Industrial Estate,
Old Dublin Road,
Enniscorthy, County Wexford, Ireland
Phone: ++353.539.233778
Fax: ++353.539.233284
sales@weberireland.com

Weber
Labels & Labeling Systems

www.weberpackaging.com

